

MODEL 361 - CODAX AUTOMATIC KEYS  
 INSTALLATION AND OPERATING INSTRUCTIONS

I DESCRIPTION

The B&W Model 361 CODAX AUTOMATIC KEYS is a fully solid-state automatic keyer designed for maximum operator convenience in CW operation. CODAX is a complete unit with its own internal battery power supply and an integral, front panel mount, double-paddle key. Only two controls are necessary. Speed (5-50 words per minute) and audio gain/"ON" - "OFF" switch. CODAX may be used with any type of transmitter - AM, CW, and SSB, without any modification to the transmitter. Interconnection between CODAX and your transmitter and receiver are by means of simple cables.

Among the novel features of CODAX are:

- 1) Provision for mixing the incoming signal from your receiver with YOUR own keying for monitoring.
- 2) Use of an ultra-reliable REED Relay for keying the transmitter ( grid-block keying).
- 3) Provision of a "keyed audio output" of 1500 cycles (nominal) at a voltage output level of .050 volts intended for insertion in microphone input on SSB transmitters, or AM transmitters operated above 50.0 MHz. for MCW service.

II CIRCUIT DESCRIPTION

For the purpose of understanding how the CODAX operates, a simplified waveform diagram and block diagram are shown in Figures 1 and 2. The complete schematic is given in Figure 3.

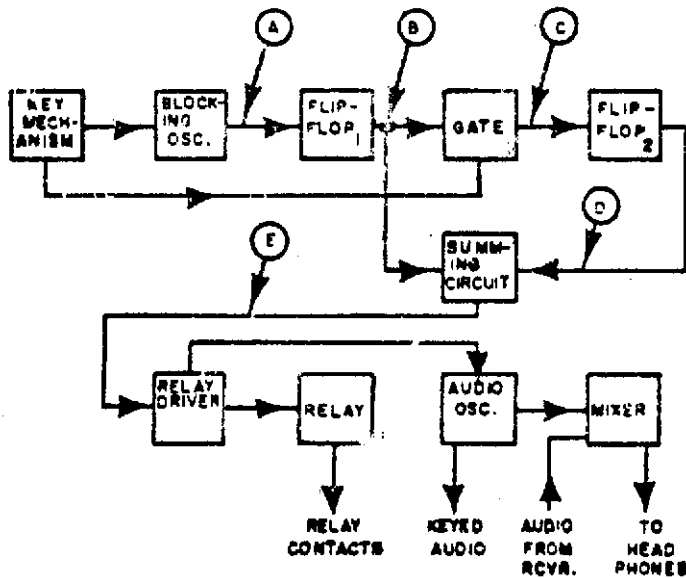

FIG.1 SIMPLIFIED BLOCK DIAGRAM

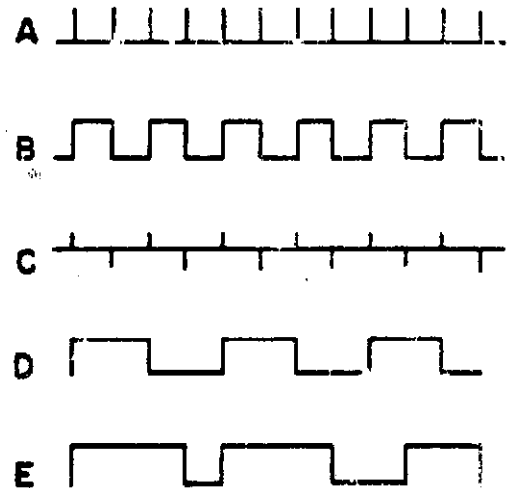

FIG. 2

The Key, either DOT or DASH, starts the blocking oscillator running at a frequency determined by the setting of the SPEED control potentiometer. The output of the blocking oscillator is a series of pulses (A). See Fig. 2. These pulses feed flip flop No. 1, which generates a DOT and a space (B) which goes into a summing circuit and then to the REED Relay Driver (E) that operates the relay at the keying rate. When it is the DASH paddle that is operated, the dot pulses are shaped and inserted into a second flip flop (D) which operates at half the frequency of the dot pulses. Its output, which is a pulse twice the length of the dot pulse, is passed through the gate which is opened by the dash paddle and is added to the DOT output in the summing circuit. The relay driver, in addition to operating the REED Relay, also operates an audio oscillator from its collector to provide the keyed audio outputs for monitoring in the mixer, and for insertion into the normal microphone input circuit of an AM or SSB transmitter. Both spacing ratios, and dot to dash ratios, are fixed for all speeds of operation. There is no waiting to "catch" the oscillator since the oscillator is always off until either paddle is pressed. Both DOTS and DASHES are self-completing and a dash may be inserted into a series of dots at any time by pressing the DASH PADDLE. The speed control knob carries an approximate speed calibration for operator convenience.

Power to operate CODAX is from six internally mounted mercury batteries (Mallory ZM-9) not furnished with the unit. Battery life will be in excess of 400 hours.

### III MATERIAL PROVIDED

- 1) CODAX Automatic Keyer and attached cables.
- 2) Installation and operating instructions.

### IV INSTALLATION

- 1) Open CODAX by removing two screws at rear of case. Slide case off to expose circuit board. Install six batteries making certain to observe polarity (+ and -) on both the batteries themselves and the battery holders. Note that with Mercury batteries the battery case is (+) and the tip is (-). The positive terminals of each holder is marked with red.
- 2) Plug cable marked "To Phone Jack" with standard phone plug into receiver headphone jack.
- 3) Plug your headphones into jack marked "Head Phones" on rear of CODAX.
- 4) (a) SSB or AM

Attach appropriate plug (to match your microphone plug) to cable marked "Keyed Audio". Insert this plug into transmitter microphone input. Disregard cable marked "To Key Term" (The REED Relay output). Using SSB with VOX, adjust VOX hold-in time to suit your operating speed. When the key is pressed for either dots or dashes, the VOX relay actuates the transmitter and mutes the receiver. Adjust receiver audio level and CODAX audio level for comfortable headphone level on both CODAX and the incoming CW signal. Set speed control to desired transmitting speed. Markings on this knob are approximate and are for reference only.

Adjust transmitter microphone gain so that on continuous dots at speed of 20 words per minute, the average final plate current is about 25% to 33% of the tuned up, loaded, full carrier value. If used with an AM transmitter (only above 50 MHz) external change-over switching from transmit to receive will be required. Transmitter microphone level should be set to avoid over modulation in same manner as used for voice transmission.

#### (b) CW Transmitters - Disregard Cable marked "Keyed Audio Output"

Connect cable marked "To Key Term" to normal transmitter key terminals. The REED Relay will handle only 15 watts of total power (keyed voltage times keyed current equals keyed watts, 15 maximum). Refer to transmitter Instruction Manual to determine type keying circuit and maximum voltage and current to be "keyed". The maximum voltage is 250 volts and the maximum current is 1000 milliamperes, but note that you may not switch more than 15 watts. In general, blocked grid circuits will be found to be within acceptable limits . . . but don't take chances - check and measure! If your keying circuit is beyond this 15 watt limit, or 250 volts, or 1000 Ma., obtain an external keying relay that will handle the power and use CODAX Reed Relay Output to control the external relay. If in doubt, we recommend that you write to our factory Amateur Service Department for "specific" connection information including in your letter complete information on make, model, and, if possible, instruction book on your particular transmitter.

### V PADDLE ADJUSTMENT

Each paddle is individually adjustable for both gap and tension. There are two screws visible at the top of the trim strip around the paddles. These are the individual adjustments for the spacing of the contacts. The two screws in the paddles themselves are used to adjust the tension of the paddles. The two adjustments are somewhat inter-dependent. It is suggested that the tension be set first and then the spacing adjusted as desired.

## VI NOTES

- 1) CODAX Automatic Keyer does not by itself provide "break-in" Keying. It will, however, usually work break-in, if break-in operation was provided initially in your transmitter installation.
- 2) Since CODAX is a solid-state device, it is well to make certain that the case of CODAX is grounded to your transmitter so that stray RF pick-up is avoided in the transistors.
- 3) CODAX makes a convenient device for tuning transmitters at high power levels when long tune-up time could injure tubes. The keyed output reduces the duty cycle during tune-up.
- 4) If Mercury batteries are not available, standard pen-light carbon zinc cells may be used but OBSERVE polarity when inserting ANY BATTERY. Mercury cells are positive case, negative tip - - - carbon zinc cells are negative (-) case and positive (+) tip. We recommend Mercury cells for longer life and constant voltage.
- 5) If you are left-handed, the double paddle can be reconnected to reverse dot and dash levers by interchanging the two wires (white with orange tracer, and white with green tracer) which will be found attached to either side of the paddle assembly inside the case.
- 6) For additional information on Keying circuits, see Radio Amateur's Handbook - Section "Keying and Break-in".
- 7) If desired, the high speed limit of 50 words per minute may be increased to 65 words per minute by shunting R-3 with 47K ohms, ¼ watt.

## ADDENDA

### 1) Specifications

Audio Input -	½ watt (maximum) at 4 to 500 ohms.
Headphone Output -	(Adjustable) 0 - .2 volts into 600 ohm phones.
Keyed Audio Output -	.050 volts, 1500 cps, nominal
Reed Relay -	15 watts (maximum) 250 volts, 1 ampere. See Text.
Paddle Pressure/Gap -	Factory adjusted to 20 grams at .001" (nominal) gap.

### 2) Additional Notes

- a) Keying - Where possible, it will always be preferable to use the Reed Relay contacts to key the transmitter because certain crystal filter or phasing-type transmitters (transceivers) will not accept any single tone keying input without putting out spurious signals that are the unwanted sideband, residual carrier, and harmonics of the keyed audio frequency.
- b) Loudspeaker Operation - The addition of a simple "phono" input to ANY communications receiver (see Fig. 4) will provide speaker operation AND headphone operation, as well as audio mixing of incoming signals and CODAX monitoring.
- c) Use of External Key - If it is desired to use an external key in place of CODAX paddles, a 3-wire cable can be installed easily in CODAX to use to connect an external key (Fig. 5).
- d) Use of CODAX Paddles - With the light pressure required to operate CODAX, no trouble will be encountered with CODAX "walking" on the table. If CODAX walks, you are not operating properly. Put your hand on the table and operate the paddles using only light FINGER pressure of the thumb and index finger . . . no wrist or arm movement to be used. Give yourself and CODAX a little practice!
- e) Keyed Audio - When VOX CW with SSB transmitters is used, keep the transmitter microphone gain control turned down so the AVERAGE transmitter plate current is no more than 25 - 33% the "loaded" value on a string of fast dots (20 w.p.m.).
- f) In order to use a manual (straight) key, follow these instructions.

Remove the cover and look at the circuitry side of the printed circuit board. Drill a 1/8" diameter hole in back panel per sketch, exercising caution when drilling. Locate the two large holes in which the Reed Relay coil is mounted. Solder one end of a 12" lead (No. 22AWG, insulated stranded wire) to the hole pad that is farthest from side edge of board, connect one end of a second lead to the ground point screw on printed circuit board. Bring both leads under the circuit board and out through the 1/8" drilled hole. Replace cover applying pressure to the front panel under the paddles. Connect the lead from the relay to one terminal of the manual key. Connect the lead from the ground point to the remaining terminal of the key.

Turn CODAX on, adjust the volume and you now have a CW monitor – CW signal mixer . . . hand key controlled AND a CODE practice oscillator. All of the keying precautions applying to CODAX still apply . . . you still key through the Reed Relay contact. With a hand key, the SPEED control knob has no effect.

